

ELECTRONIC VARIABLE VOLUME DIFFUSER

VCD,VRD,VSD1

- ✿ VAV DIFFUSERS PREVENT DUMPING
- ✿ VAV DIFFUSERS SAVE FAN ENERGY
- ✿ HEATING AND COOLING
- ✿ EXCELLENT THROW & FLOW
- ✿ HIGH INDUCTION RATES
- ✿ NO MAINTENANCE
- ✿ ACCURATE ONBOARD SENSING
- ✿ ENERGY SAVING - LOW PRESSURE LOSS
- ✿ WIDE RANGE
- ✿ ADJUSTABLE MIN & MAX FLOW
- ✿ 2 YEAR WARRANTY
- ✿ REHEAT, OCCUPANCY, FLOW MEASUREMENT

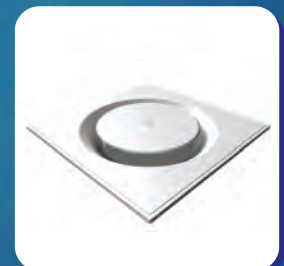
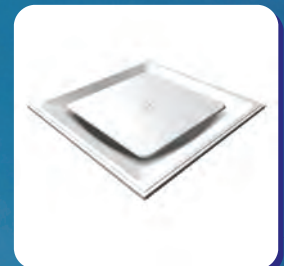

FEATURES

Rickard VAV Diffusers control Room Temperature by adjusting the volume of air at the diffuser outlet. By changing the diffusers exit geometry, Coanda, Air Velocity and Throw is maintained at minimum and maximum volume. This technology prevents cold air from dumping at minimum, ensures excellent ventilation, air mixing, Air Change Effectiveness (ACE) and therefore thermal comfort (ADPI). Rickard VAV diffusers reduce pressure loss in the system due to their aerodynamic design and the absence of restrictions in the duct work.

PERFORMANCE

Rickard VAV Diffusers control Room Temperature by adjusting the volume of air at the diffuser outlet.

By changing the diffusers exit geometry, Coanda, Air Velocity and Throw is maintained at minimum and maximum volume.

This technology prevents cold air from dumping at minimum, ensures excellent ventilation, air mixing, Air Change Effectiveness (ACE) and therefore thermal comfort (ADPI).

Rickard VAV diffusers reduce pressure loss in the system due to their aerodynamic design and the absence of restrictions in the duct work.

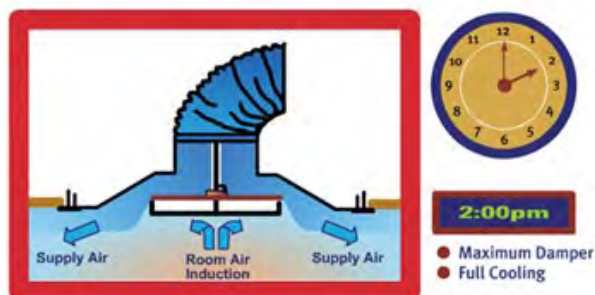
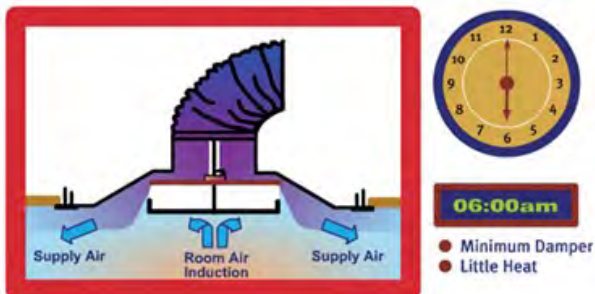

ENERGY SAVINGS

Green Building Benefits. Receive Management, Indoor Environmental Quality and Energy Efficiency Credits by using Rickard VAV Diffusers.

Rickard MLM controls use energy efficiently. Rickard MLM Diffusers use -2.4VA (24VDC 100mA) only when the motor is running. MLM24 Power Supply Units use - 40VA (220VAC .2A) or (115VAC .35A) max and can supply up to 15 diffusers. MLM Master Communications Units (MCU2) use - 10VA (24VAC .4A) max and can connect to 60 diffusers.

ONBOARD SENSING ACCURACY

Rickard Diffusers use innovative forced induction technology resulting in accurate room sensing and flexible zoning.

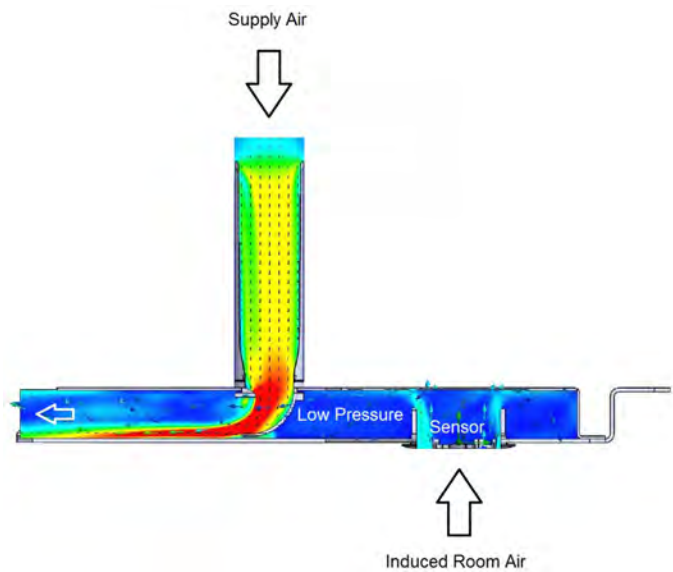

CONTROLS

Master/Slave changes are achieved by installing an onboard controller that is accessible from below the ceiling and is activated using Rickard's Free Software.

Electronically adjustable maximum and minimum control disc limits allow designed airflow volumes to be achieved.

Global manual commands (all diffusers can be driven open) reduce commissioning costs.

Cost effective standalone, LonWorks and BACnet integration.

CAPITAL AND OPERATING COSTS

Low diffuser height (100mm) can reduce a buildings overall cost by reducing the height of the ceiling void.

INSTALLATION AND SAVINGS

Included plastic packaging can be used to protect the Tile once installed.

Light weight Diffuser. Tile can be installed separately if required.

Our diffuser range fits most ceiling styles.

MAINTENANCE

No regular maintenance is required.

Working components are all accessible from below the ceiling. No skilled labour or special tools are required.

Diffuser life cycle testing gives peace of mind far beyond our two year warranty period (Electronic diffuser range). Life cycle testing is based on 3000 operating hours and 4000 control cycles per year and is the equivalent of 30 years of service.

AESTHETICS

The Rickard range of ceiling diffusers offers a clean uncluttered look. The design hides the internals, is pressed to lie flush with the ceiling and comes in a range of colours and styles to satisfy different tastes.

WARRANTY

Rickard offers a 2 year manufacturer's warranty on its Electronic VAV diffusers. Please see Terms and Conditions for a full description of our Warranty.

SAFETY

Working plastic components are moulded in glass reinforced Makrolon - Makrolon is flame retardant and chlorine and bromine free when burnt. The Rickard Thermo-Disc and Electronic actuators are moulded in Makrolon and are UL Certified.

Stainless Steel safety cable supports the working sub-assembly when detached from the back pan.

APPLICATION

VAV COOLING AND HEATING

VAV COOLING WITH TERMINAL REHEAT

The RICKARD VARIABLE GEOMETRY VARI-DISC CEILING DIFFUSER is designed for general building zones where uniform radial discharge is the most suitable and desirable supply air distribution pattern. The basic diffuser is available in a wide range of options to suit every individual requirement.

Optimum performance in terms of uniform air distribution and low noise levels have been combined with simple construction and aesthetically pleasing appearance to provide a unit which is both functional and reliable. All diffusers are of steel construction and are finished in a chip resistant baked epoxy coating which is available in a wide range of colours to suit architectural requirements.

OPERATION

TEMPERATURE CONTROL

Room temperature is controlled by varying the supply air volume in accordance with demand. Volume control is achieved by moving a disc, known as a control disc, vertically up and down within the diffuser so as to vary the aperture through which the air passes. This is effectively what constitutes the "VARIABLE GEOMETRY" concept which maintains acceptable air movement in the room throughout the range from 100% down to as little as 25%.

The position of the control disc is varied by means of an electric actuator which drives the control disc in response to a signal received from a temperature controller. When used in conjunction with one of the RICKARD controllers, the diffuser will control room temperature on a proportional/integral basis. Air is discharged in a horizontal 360° pattern. Used in conjunction with our MLM controls, maximum and minimum supply air volumes may be adjusted to suit the particular design conditions.

In some cases, extra heating may be required in a particularly cold office or corner of the building. In these cases top-up heaters are available. Rickard's top-up heaters are modular and are easily added to a diffuser to ensure an occupants comfort levels are satisfied.

SENSING

Rickard offer a number of temperature sensing/controller options: On-board controller and sensing located on the diffuser for maximum floor layout flexibility. A wired wall thermostat with combined controller, sensor and set-point adjuster giving the occupant maximum control and sensing accuracy with slightly less layout flexibility. An on-board controller and sensing with remote infra-red set-point adjuster for maximum flexibility and individual temperature control. An on-board controller with wired remote sensing for exceptionally accurate room sensing. Please see the following Catalogue Sections for more information: Room Sensing Options, Wall Thermostat, Hand-held Infra-red Set Point Adjuster, MLM and MLC Controls Sections.

SELECTION

GENERAL

The first consideration when designing a system is to calculate the required supply air volume and temperature to satisfy room conditions at maximum heat loads. It is recommended that ducting is sized using static regain design principles. Supply air velocities in branch ducts should be between 3.5 and 7.5m/s (650 and 1500ft/min).

THROW

This is the distance from the centre of the diffuser to the point at which the supply air velocity has reduced to 0.25m/s (50ft/min) when measured 25mm (1 inch) below the ceiling and the control disc is in the fully open position. Coning occurs when two airstreams travelling in opposite directions meet and result in a downward moving cone of air. A similar effect is experienced should a diffuser be positioned at a distance from the wall that is less than its throw. The air will strike the wall and flow in a downward direction such that the point at which the air reaches a velocity of 0.25m/s (50ft/min), the sum of the horizontal and vertical travel of the air is equal to the diffuser throw. Throw remains at acceptable levels throughout the range of air flows, a feature of the variable geometry VAV diffuser concept.

DETERMINING MAXIMUM CEILING HEIGHT

The drawing below describes how to determine the maximum ceiling height that can be achieved from a diffuser. Please see the diffuser performance data page for airflow, throw, noise and pressure information.

NOISE LEVEL REQUIREMENTS

The published diffuser noise level must be checked to ensure it is within the project specification. Published diffuser noise levels represent only the noise generated by the diffuser and do not take into consideration any duct-borne noise.

DUCT STATIC PRESSURE

Diffuser performance has been established using diffuser neck TOTAL pressure, although that which is normally known or measured is duct STATIC pressure. What happens between the duct and the diffuser depends on the length and type of flexible duct being used. For simplicity, it can be assumed that the duct STATIC pressure is approximately equal to the diffuser neck total pressure. This is a valid assumption for systems where flexible duct lengths are not excessive and can be explained briefly as follows:





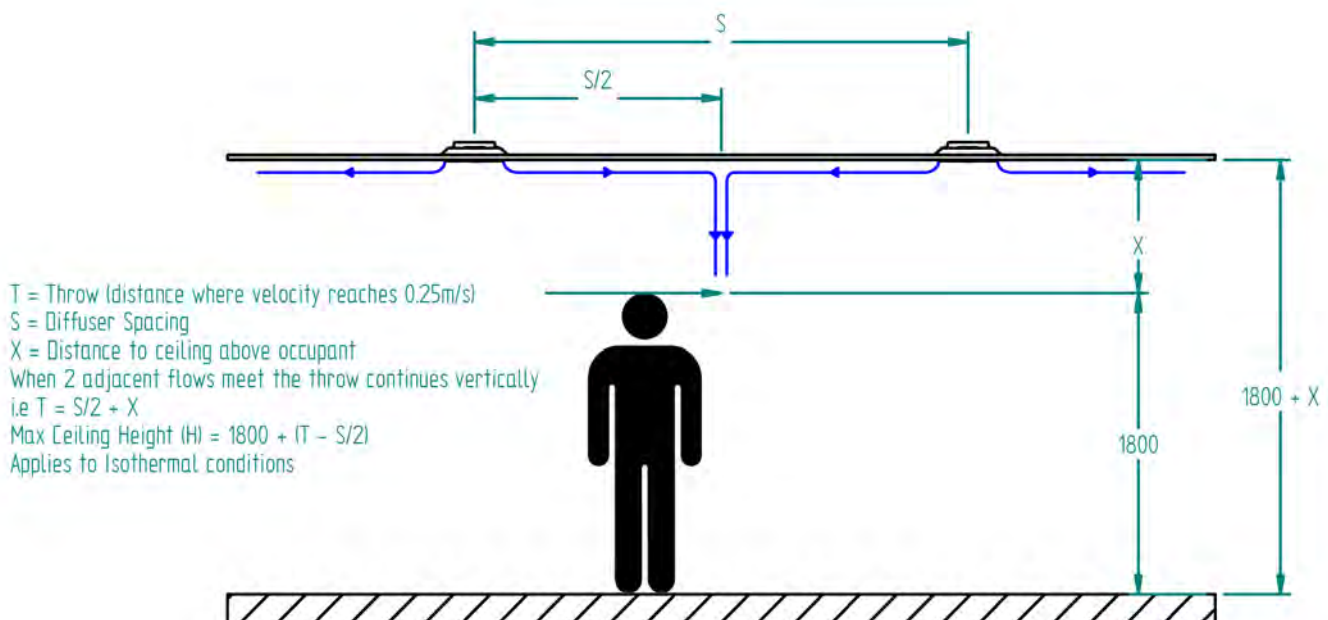

The static pressure loss due to friction in the flexible duct ($\pm 10\text{Pa}$ or 0.04ins Wg) would normally be about the same as the velocity pressure in the neck of the diffuser and since total pressure is the sum of static and velocity pressure, we can say that neck total pressure is numerically approximately the same as duct static pressure. Although the tables reflect diffuser performance for neck total pressures ranging from $20\text{-}100\text{Pa}$ ($0.04\text{-}0.40\text{ins Wg}$), caution should be exercised when selecting diffusers outside the $40\text{-}80\text{Pa}$ ($0.08\text{-}0.32\text{ins Wg}$). At lower pressures air movement and induction may be insufficient and at higher pressures draughts and excessive noise may result. Best results are obtained when diffusers are selected at pressures of $40\text{-}60\text{Pa}$ ($0.08\text{-}0.24\text{ins Wg}$). Bear in mind that all diffusers served by a common duct will all operate at the same static pressure as controlled by the pressure control damper. Therefore diffusers which are able to supply more air than is necessary will be driven partially-closed by the temperature controller and hence the system becomes self-balancing.

NOTE: Avoid upstream restrictions such as manually adjusted dampers or squashed flexible ducting. The reason being that at maximum flow any restrictions will result in a significant static pressure loss (which for some cases may be desirable) whereas at minimum flow conditions offer virtually no restriction, which will result in the static pressure at the diffuser being too high at minimum flow causing over-cooling/heating.

DETERMINING MAXIMUM CEILING HEIGHT

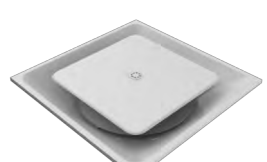

TYPES

<p>VCD1 LARGE CONE 350mm only S595 & 603</p> 	<p>VCD1 MEDIUM CONE 150mm to 300mm S495, 595 & 603</p> 
<p>VRD1 LARGE CONE 350mm only R580mm</p> 	<p>VRD1 MEDIUM CONE 150mm to 300mm R580mm</p> 
<p>VSD1 LARGE CONE 150 to 350mm S595 & 603mm</p> 	<p>VSD1 MEDIUM CONE 150 to 300mm S495mm only</p> 
<p>VSD1 SMALL CONE 150mm S320-340mm</p> 	

On-board controller

On-board controller with remote sensor

On-board controller with infra-red remote set point adjuster

INFRA-RED REMOTE SET POINT ADJUSTER (MLM & ML)

AIRFLOW MEASUREMENT (MLM ONLY): Electronic commissioning and minimum and maximum airflow limits for the life of the system.

OCCUPANCY SENSING (MLM ONLY): Save fan energy by closing the diffuser when a zone is unoccupied.

LIGHTS SWITCHING (MLM ONLY): Use the existing MLM Controls system with Occupancy Sensing to switch off the lights when a zone is unoccupied.

JUBILEE CLAMP: Saves time and material when attaching the flex.

VARIOUS CEILING DIFFUSER MOUNTING STYLES AVAILABLE: See Ceiling Diffuser Mounting Methods in this Catalogue Section.

BLANKING PLATES: 90, 180 or 270 degree Blanking Plates

OPTIONS

CONTROLS

- MLM (Multi-loop Modular Controls)
- ML (Multi-loop Controls)

REVERSING CHANGEOVER FOR HEATING AND COOLING MODES (MLM & ML)

ELECTRIC HEATING (MLM & ML): Modular re-heaters can be added to a diffuser to supply spot heating in cold zones that aren't satisfied by the supply air.

DIFFUSER SENSING/CONTROLLER OPTIONS (MLM & ML)

Wall thermostat/controller

Small Cone		VSD					
SIZE	READING	NECK TOTAL PRESSURE (Pa)					
		20	30	40	50	60	70
150	FLOW l/s	61	74	85	95	104	110
	THROW m	1.89	2.16	2.48	2.62	2.77	2.81
	NC LEVEL	32	34	37	39	41	43

Medium Cone		VCD, VRD					
SIZE	READING	NECK TOTAL PRESSURE (Pa)					
		20	30	40	50	60	70
150	FLOW l/s	64	78	91	101	111	118
	THROW m	2	2.1	2.7	3	3.3	3.5
	NC LEVEL	-	-	-	-	26	28
200	FLOW l/s	107	127	147	165	180	195
	THROW m	2	2.6	3	3.2	3.6	3.9
	NC LEVEL	-	27	28	29	30	33
250	FLOW l/s	154	188	214	241	265	287
	THROW m	2.4	2.6	3.2	3.5	3.9	4.2
	NC LEVEL	-	27	29	31	33	36
300	FLOW l/s	191	235	273	306	336	364
	THROW m	2.5	2.8	3.3	3.7	4.2	4.6
	NC LEVEL	27	28	30	32	35	37

Large Cone		VCD350, VSD150-350 & VRD350					
SIZE	READING	NECK TOTAL PRESSURE (Pa)					
		20	30	40	50	60	70
150	FLOW l/s	62	76	88	98	108	115
	THROW m	2	2.1	2.7	3	3.3	3.5
	NC LEVEL	-	-	-	-	26	28
200	FLOW l/s	108	131	151	169	185	199
	THROW m	2	2.6	3	3.2	3.6	3.9
	NC LEVEL	-	27	28	29	30	33
250	FLOW l/s	145	176	201	226	249	270
	THROW m	2.4	2.6	3.2	3.5	3.9	4.2
	NC LEVEL	-	27	29	31	33	36
300	FLOW l/s	176	211	245	275	302	327
	THROW m	2.5	2.8	3.3	3.7	4.2	4.6
	NC LEVEL	27	28	30	32	35	37
350 ELECTRONIC ONLY	FLOW l/s	242	298	345	389	429	465
	THROW m	2.7	3.2	3.6	4.1	4.5	5
	NC LEVEL	27	28	30	32	35	38

Throw data is taken 25mm below the ceiling on a line through the centre of the diffuser with the control disc fully open & an air velocity at 0.25m/s.

Noise Criteria levels apply to a single diffuser mounted in a room having a Sound Absorption of 10dB in octave bands having centre frequencies from 125Hz to 8000Hz (i.e. the difference between Sound Pressure Level (dB re:2 x 10⁻⁵ Pa) and Sound Power Level (dBW re: 10⁻¹² watts) is equal to 10dB). These levels represent only the noise generated by the diffuser and do not take into account any duct-borne noise.

Diffusers are factory set for a minimum of 30% of the maximum flow levels reflected above. It should be noted that minimum diffuser air flow settings are approximate & may require to be reset on site to compensate for actual site system pressures.

Performance Data applies to Standard Air having a density of 1.2 kg/m³.

GREEN BUILDING BENEFITS

INTRODUCTION

There is an increased focus on green in modern buildings, and a focus to improve the green rating of existing buildings.

This section highlights how Rickard product may help to get a building project certified as green.

Rickard low pressure VAV diffusers can have an impact the following green credits

- Management credits
- Indoor Environmental Quality credits
- Energy credits

MANAGEMENT CREDITS

BUILDING TUNING

Diffusers are self balancing, and fine-tune air delivery to the precise needs of the office.

This is achieved through the modulation of a diffuser control disc that is activated by electronic controls to ensure that the correct amount of air is released into the room thereby controlling room conditions.

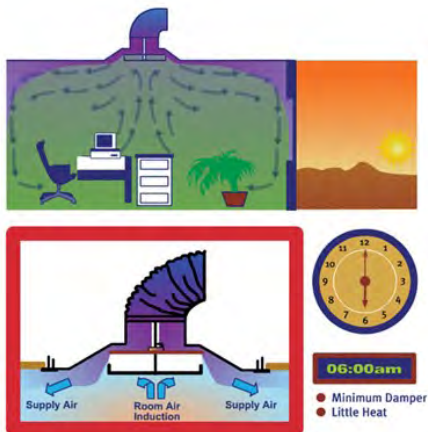

COMMISSIONING

Since these diffusers are essentially self balancing, there is no need to balance the airflow to every variable geometry diffuser. The commissioning engineer need only ensure that the diffuser most likely to be starved from air, typically at the end of the run, has enough air at maximum load conditions.

INFORMATION MANAGEMENT

Modern BMS compatible VAV diffuser controls allow for intelligent building and central plant decisions based on information available from every diffuser. Building conditions can be controlled and modified centrally. See MLM controls booklet for more information.

INDOOR ENVIRONMENTAL QUALITY CREDITS

INDIVIDUAL COMFORT CONTROL

Every Variable Geometry VAV diffuser can individually control conditions in the occupied space where it is fitted. Every diffuser can be fitted with an on-board space sensor, or a Wall mounted space sensor with set point adjustment capabilities.

THERMAL COMFORT

Compliance with Ashrae 55-1992 is possible when using VAV diffusers. A VAV Diffuser is the only HVAC product that directly effects comfort.

AIR CHANGE EFFECTIVENESS

Rickard VAV diffusers will ensure that air is mixed effectively in the occupied space even when supplying Minimum Air volumes

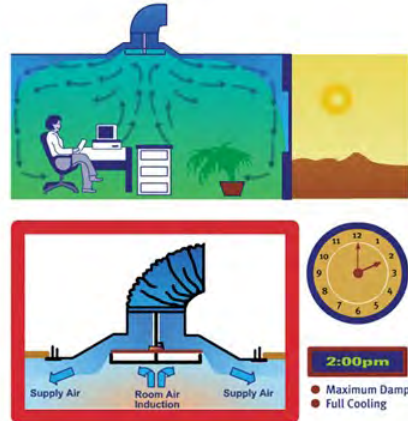

ENERGY CREDITS

ENERGY IMPROVEMENT

Low Pressure VAV diffusers save energy due to the following benefits:

- Rickard VAV diffusers eliminate the pressure drop associated with VAV boxes required in a VAV box variable volume air supply system. This result in a central plant that use less Fan energy.
- Rickard VAV diffusers save energy since no area in the building is over cooled, or over heated. Every diffuser measures local space conditions and varies the amount of air to meet the demands of that area.
- Rickard VAV diffusers with occupancy sensors ensure that only occupied spaces are supplied with air. This can save a huge amount of fan energy since only 50% to 70% of space, depending on the type of building, is occupied at any one time during business hours.

ELECTRICAL AND TENANCY SUB-METERING

Sub-metering can be achieved because Rickard Controls and Neck Heaters are powered via separate circuits.

PEAK ENERGY DEMAND REDUCTION

Heating on different diffusers can be staggered to reduce total building peak demand.

Heater output can be limited per zone or per diffuser to reduce power requirements during peak demand periods.

THROW AND EXIT VELOCITY

It is a feature of the variable geometry VAV diffuser concept to maintain throw at an acceptable level throughout the range of air flows. This is achieved by changing the exit geometry for reduced airflow. This maintains the exit velocity, which in return will maintain the throw. Throw is the distance from the diffuser at which the air velocity drops below 0.25 m/s.

If air velocity is too high in the occupied space, drafts will be experienced and ADPI values will suffer.

VAV diffusers rely on a high velocity air stream to maintain coanda and throw next to the ceiling. Care must be taken to select the correct diffuser for the size of the space and to meet load requirements.

Correctly selected diffusers allow for effective room air circulation without drafts as shown in the CFD analysis below.

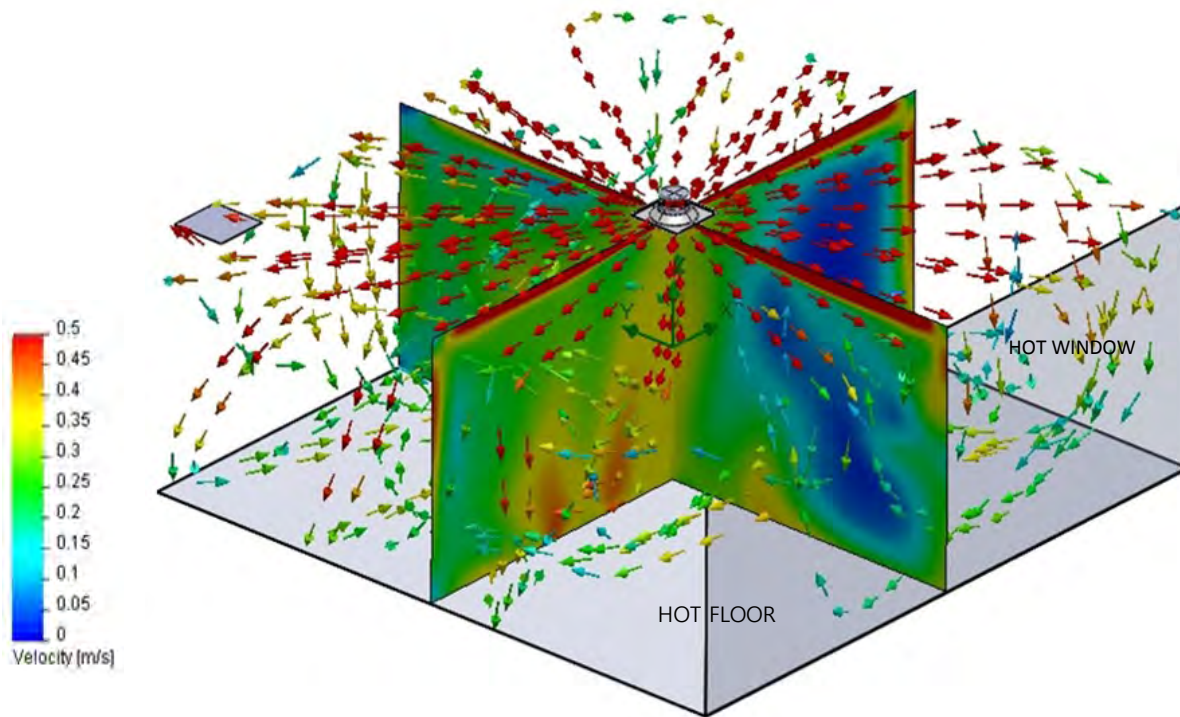

VELOCITY VECTOR PLOT (VCD 300mm; Control Disc 30% open; Supply 12°C; Room 7m x 7m)

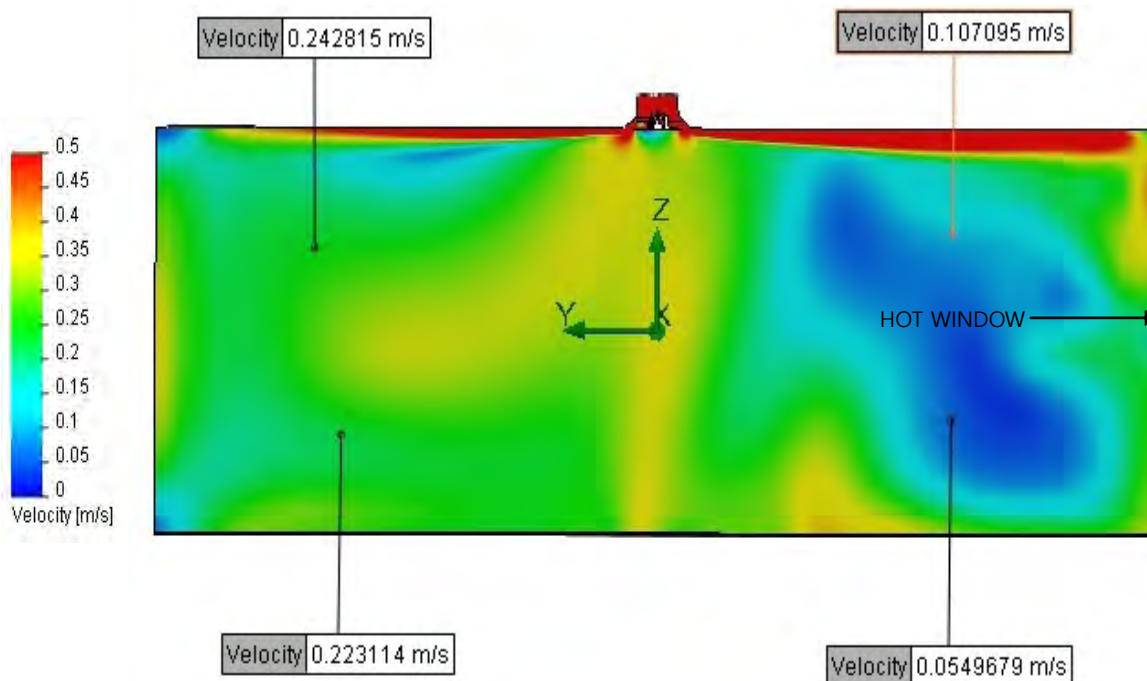

VELOCITY VECTOR PLOT (VCD 300mm; Control Disc 30% open; Supply 12°C; Room 7m x 7m)

AIR CHANGE EFFECTIVENESS

Air Change Effectiveness (ACE), is defined as the age of air that would occur throughout the room if the air was perfectly mixed, divided by the average age of the air that occupants would inhale.

An Air Change Effectiveness of 1 indicates perfect uniform mixing in the room. If ACE is lower than 1, it is an indication that the air is short-circuiting between the supply air diffuser and the return air grill.

An ACE value of higher than 1 is possible when air diffusion allows a higher ventilation rate in the occupied space than in the rest of the room.

Low Pressure VAV diffusers maintain acceptable Air Change Effectiveness values even when turned down to minimum supply air volumes.

The CFD clip below gives an representation of the Mean Age of the Air throughout a typical room that is fitted with a Variable Geometry VAV diffuser.

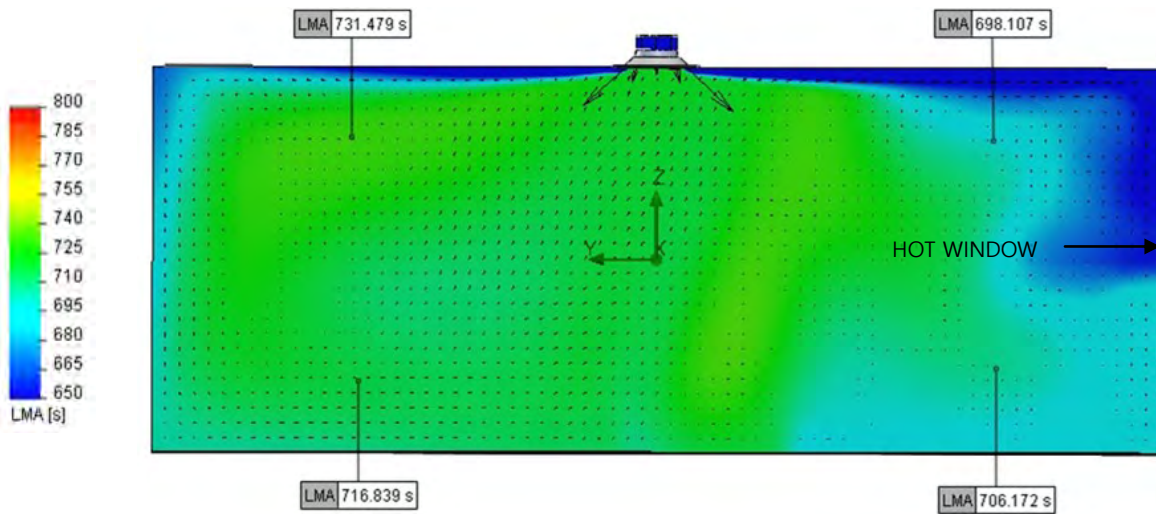

LOCAL MEAN AGE OF AIR (VCD 300mm; Control disc 30% open; Supply 12°C; Room 7m x 7m)

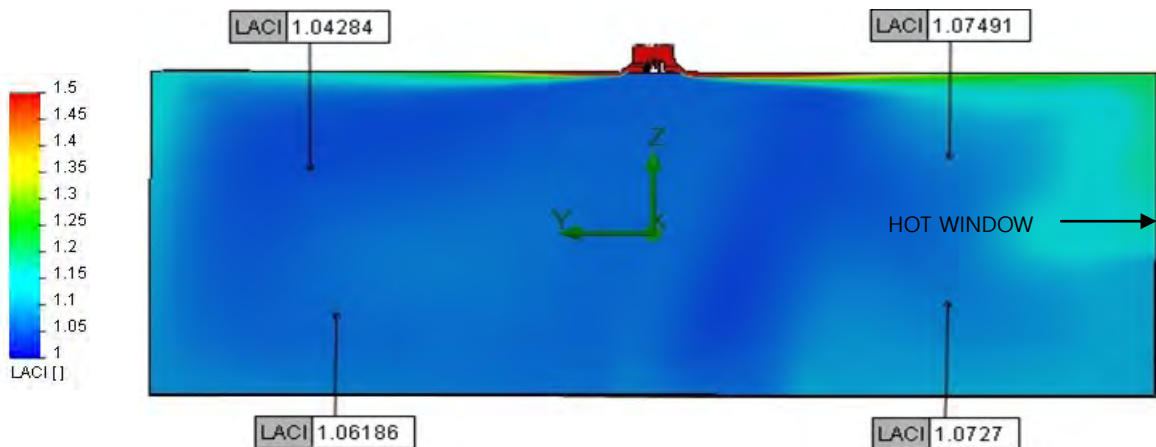

LOCAL AIR CHANGE INDEX (VCD 300mm; Control Disc 30% open; Supply 12°C; Room 7m x 7m)

LACI close to 1 indicates acceptable room air mixing

$$LACI = LMA / \text{time taken to fill room with air}$$

ADPI PERFORMANCE

Air Diffusion Performance Index (ADPI) statistically relates the air temperature and air speed in the occupied space to the occupants' thermal comfort.

ADPI is calculated as the percentage of locations in the conditioned space that meet comfort standards.

The "2009 Ashrae Handbook: Fundamentals" indicates that conditions in the occupied space is acceptable when:

- the air velocity is below 0.35 m/s
- the effective draft temperature is larger than -1.5 and smaller than 1. The effective draft temperature is calculated around setpoint. (Tc is 22°C in the plot below)
- the Draft Rating is smaller than 20. The Draft Rating is the number of people that would be uncomfortable due to draft.

Rickard VAV diffusers that are correctly selected for the size of the occupied space and the load in the occupied space, will maintain good ADPI values throughout the range of control disc movement.

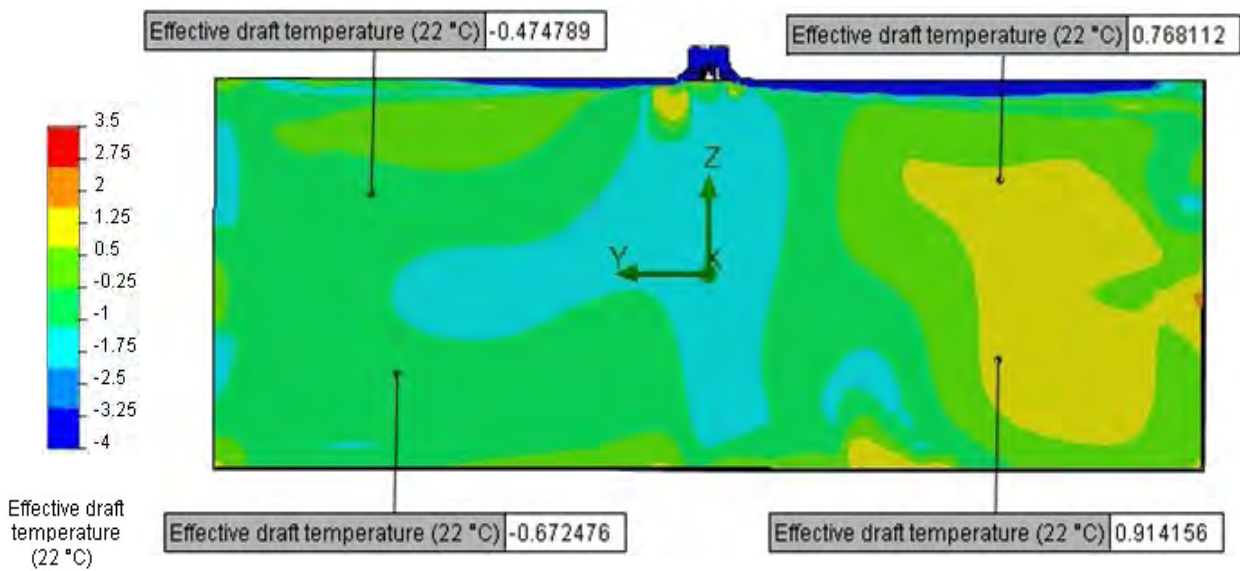

EFFECTIVE DRAFT TEMPERATURE (VCD 300mm; Control Disc 30% open; Supply 12°C; Room 7m x 7m)

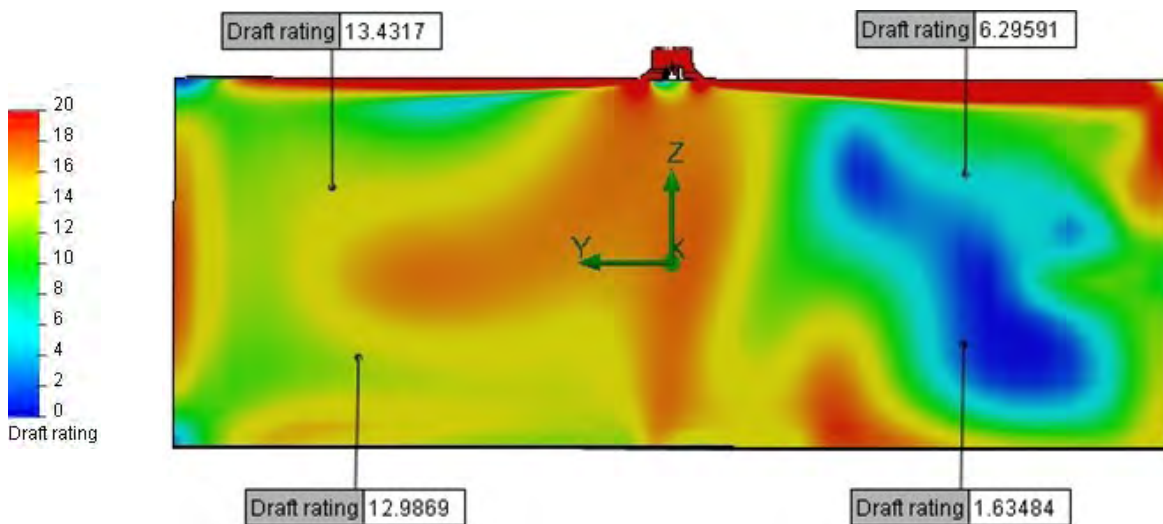

DRAFT RATING (VCD 300mm; Control Disc 30% open; Supply 12°C; Room 7m x 7m)

OPTIONS

The Rickard Ceiling Diffuser Range supports a wide range of diffusion unit styles.

EXPOSED TEE CEILING GRID

1. SQUARE DIFFUSER
 - i. Drop-in Flush Mounting
 - ii. Drop-in Shadow Line

The basic diffuser usually drops into a square opening between ceiling tees. Flush Mounting and Shadow Line styles are available. These can be supplied with the following mounting plate sizes, 495x495mm, 595x595mm & 23³/₄x23³/₄" to suit 500x500mm, 600x600mm & 24x24" ceiling grids respectively. Specials sizes are available on request.

DROP-IN EXPOSED TEE



PLASTERED CEILING

SHADOW LINE EXPOSED TEE



SHADOW LINE EXPOSED TEE

BAFFLED CEILING OR MOUNTING IN FREE SPACE

1. SQUARE DIFFUSER
 - i. 4 Point Fixing (4 Brackets for threaded rod connection)
2. ROUND DIFFUSER
 - i. 3 Point Fixing (3 Brackets for threaded rod connection)
 - ii. Hard Duct Connection (no accessories required)

Baffled ceilings require an unusual treatment which is not illustrated. Normally this ceiling requires a square tile with suspension points fitted at each corner thereby enabling support from the top edges of the baffles. Large diffuser mounting plates are particularly beneficial in the baffled ceiling as there is otherwise little opportunity for the Coanda effect to help distribute conditioned air across the ceiling. This may result in inadequate throws and poor room air movement.

PLASTERED CEILING

1. SQUARE DIFFUSER
 - i. 4 Point Fixing (4 Brackets with Backing Plates)
 - ii. T-Frame (Square Frame to allow Drop-in Flush Mounting)

In the case of mounting square diffusers into plastered ceilings, two methods of fixing may be used. Concealed fixing is achieved by four fixing studs secured in the corners of the mounting plate. These pass through the ceiling and, with the use of backing plates, are used to secure the diffuser to the ceiling. A further option for fixing into a plastered ceiling is with the use of a T-frame which is an optional extra. This is fixed to the ceiling and the diffuser then drops into it.

4 POINT FIXING (4 BRACKETS WITH BACKING PLATES)

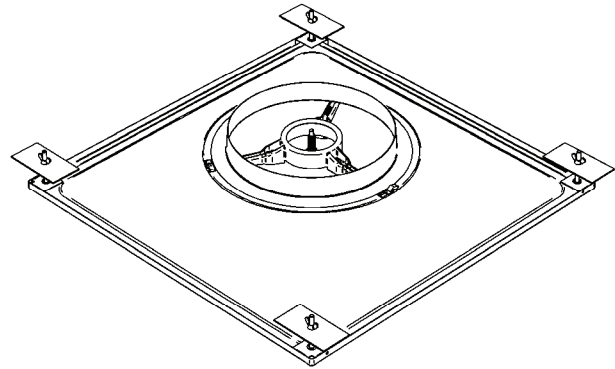

T-FRAME (DROP-IN MOUNTING FOR PLASTERED CEILINGS)

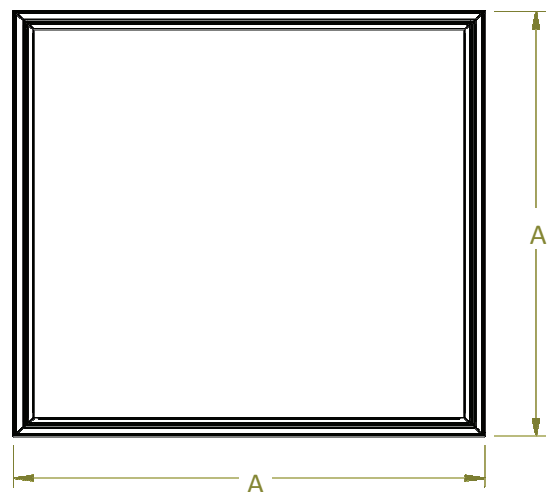
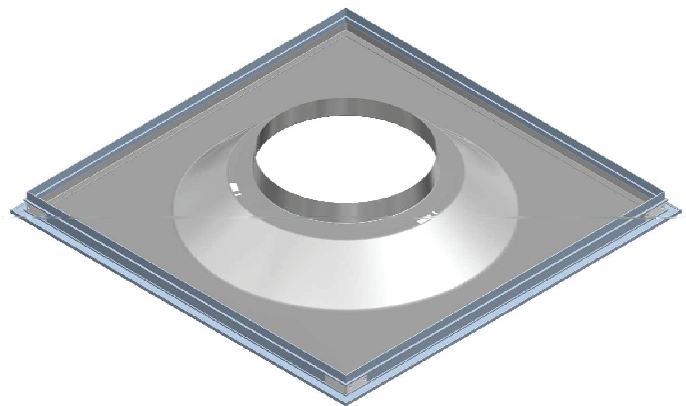
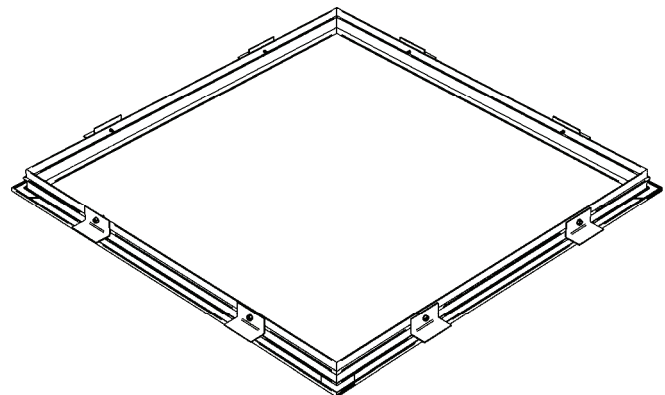

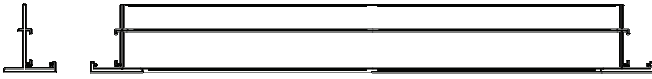

Tile Size (mm)	A (mm)
320 x 320	361
495 x 495	536
550 x 550	591
595 x 595	636
603 x 603	644
845 x 845	886

Tile Size (mm)	Ceiling Hole Dimensions (mm)
320 x 320	342 x 342
495 x 495	517 x 517
550 x 550	572 x 572
595 x 595	615 x 615
603 x 603	625 x 625
845 x 845	867 x 867

- 2. ROUND DIFFUSER
 - i. 3 Point Fixing (3 Brackets to allow Bayonet attachment)
 - ii. T-Ring (Circular Frame to allow Drop-in Flush Mounting)

Apart from the usual four-corner style, the Rickard Ceiling Diffuser is also available in a circular format. This model is most often combined with round down-lighters to preserve the circular pattern, and in particular with plastered ceilings. It also offers the absolute minimum interruption to the ceiling for those who prefer to have its unbroken regularity maintained.

Fixing of round diffusers in a plastered ceiling often presents a problem because of restricted access to the ceiling void. This problem is overcome with a diffuser that is fitted with three clips that allows the Diffuser to be twisted and clipped into a hole created in the ceiling. The installer need only cut a round hole with three notches (stencils provided with each order) and the diffuser twisted into place. Removal is as easy, a simple twist in the opposite direction and the round diffuser can be removed. The entire operation can be carried out without ever needing to enter the ceiling space.



PLASTERED CEILING CUT-OUT DETAIL FOR ROUND DIFFUSERS

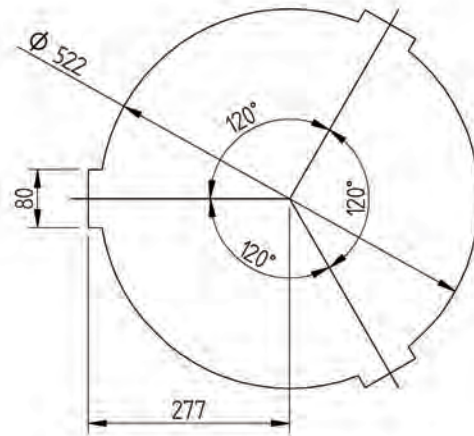

Alternatively, a T-Ring is available to allow Drop-in Flush Mounting of a standard Round Diffuser. The T-Ring is mounted flush with the ceiling after a round hole with a diameter of 590-600mm is cut into the plaster board. Four threaded brackets draw the T-Ring flush against the ceiling to ensure a neat finish.

T-RING (DROP-IN MOUNTING FOR PLASTERED CEILINGS)

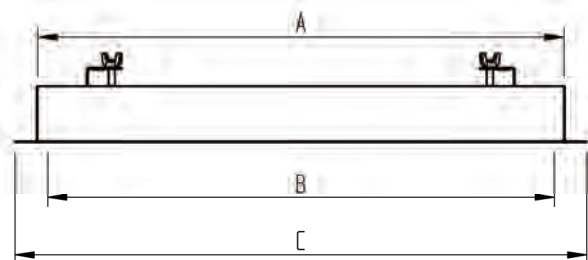

T-RING GENERAL DIMENSIONS					
NOMINAL SIZE	A	B	C	DIFFUSER DIAMETRE	CUT-OUT SIZE
580	585	565	625	580	600

CEILING DIFFUSER GENERAL DIMENSIONS

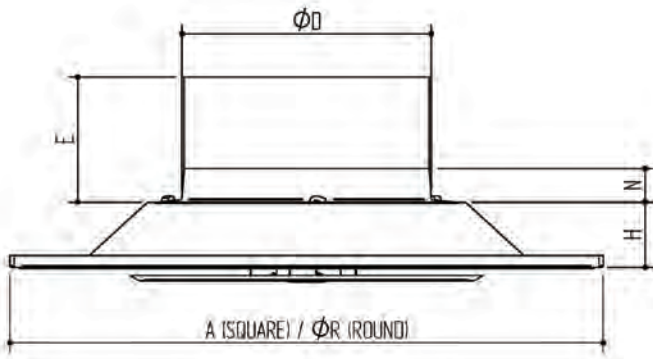

Nominal Size	Dimensions (mm)							
	Ø D	A	H	N	Ø R	E		
						Heater	Airflow Sensor	Airflow Switch
150	153	495 x 495	74	28	580	95	130	118
		595 x 595						
200	200	495 x 495	71	33				
		595 x 595						
250	250	495 x 495	66	34				
		595 x 595						
300	293	495 x 495	65	35				
		595 x 595						
350	346	595 x 595	63	43				

CEILING DIFFUSER WITH PLENUM GENERAL DIMENSIONS

(Used when ceiling space is limited)

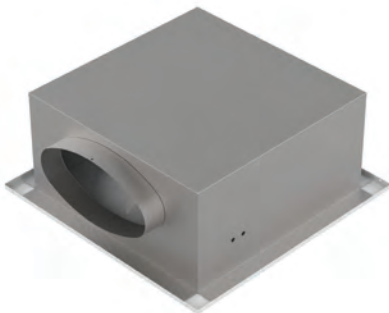
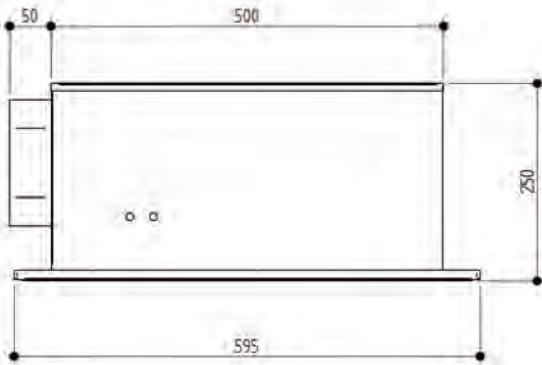

Note: Plenums create a significant pressure drop
(Performance data will not apply)

Diffuser Style				Ceiling Diffuser Mounting Types							
				Exposed Tee		Baffled Ceiling		Plastered Ceiling Surface Mounting			
Model	Diffuser Shape	Diffuser Size	Neck Size	Drop-in Flush Mounting	Drop-in Shadow Line	4 Point Fixing Brackets	3 Point Fixing Brackets	4 Point Fixing & Backing Plate	3 Point Bayonet Fixing	T-Frame	T-Ring
CCD3 MC VCD1/4/5 MC	Square	495x495	150-300	•	○	•	○	•	○	•	○
	Square	595x595	150-300	•	•	•	○	•	○	•	○
	Square	23¾"x23¾"	6-12"	•	•	•	○	•	○	•	○
CCD3 LC	Square	595x595	350	•	○	•	○	•	○	•	○
VCD1 LC	Square	23¾"x23¾"	14"	•	○	•	○	•	○	•	○
CSD3 SC VSD1/4/5 SC	Square	320x320	150	•	○	•	○	•	○	•	○
CSD3 LC	Square	595x595	150-350	•	○	•	○	•	○	•	○
VSD1 LC	Square	23¾"x23¾"	6-14"	•	○	•	○	•	○	•	○
VSD4/5 LC	Square	595x595	150-300	•	○	•	○	•	○	•	○
	Square	23¾"x23¾"	6-12"	•	○	•	○	•	○	•	○
CRD3 VRD1/4/5	Round	580	150-300	○	○	○	•	○	•	○	•
CRD3 LC VRD1 LC	Round	580	350	○	○	○	•	○	•	○	•

Ceiling Diffuser Naming Convention													
C	V	C	R	S	D	W	1	3	4	5	SC	MC	LC
Constant / Variable Volume		Trim Plate			Diffuser Type		Actuator Type				Cone Size		
Constant	Variable	Round	Round	Square	Diffuser	Swirl	Electronic	Manual	Thermal Cooling Only	Thermal Heating & Cooling	Small Cone	Medium Cone	Large Cone
		Back-pan Shape											
		Square	Round	Square									

e.g. VCD1 MC

C	V	C	R	S	D	W	1	3	4	5	SC	MC	LC
Constant / Variable Volume		Trim and Cone Shape			Diffuser Type		Actuator Type				Cone Size		
Constant	Variable	Round	Round	Square	Diffuser	Swirl	Electronic	Manual	Thermal Cooling Only	Thermal Heating & Cooling	Small Cone	Medium Cone	Large Cone
		Outside Back-pan Shape											
		Square	Round	Square									
	V	C			D		1					MC	
	Variable Volume	Round Trim Plate			Diffuser		Electronic					Medium Cone	
		Square Back-pan											

Electronic Variable Volume Diffuser with Square Back-pan, Round Medium Cone Trim and Cone

FORM FACTOR

RICKARD ceiling diffusers may be fitted with electric re-heaters that are housed within a sleeve which slides into the diffuser neck. This applies to ceiling diffuser types VCD1, VSD1, CCD3, CSD3, VSW1 and CSW3's. The heaters are energised when additional heating is required in a room. Heaters fitted into WBD's and VLN's are not modular and are fitted to the diffusers casing or spigot respectively.

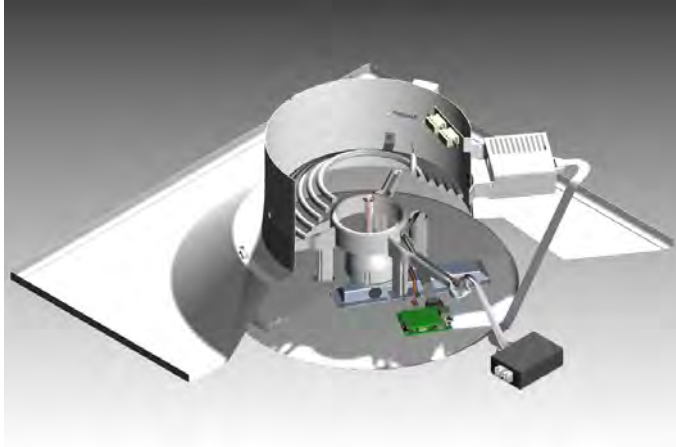

VAV PLATE DIFFUSER FITTED WITH MODULAR HEATER SPIGOT



WBD WITH DEDICATED HEATER FITTED

If used correctly, electric heating in VAV diffusers can be considered to be an energy saving device. By using them in offices that are typically colder than the building average allows the central plant to produce less heating in winter than is otherwise possible.

The most efficient scenario in heating is for the central plant to supply sufficient heated air to allow most of the zones to be in control when the diffusers damper is close to minimum position. Zones that are colder are controlled by the diffuser opening further. Zones that cannot be satisfied by the diffuser supplying warm air at full volume are topped up with supplementary heating.

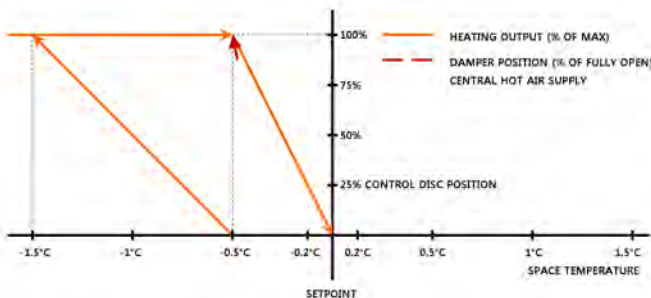

The most efficient scenario in cooling is for the central plant to supply sufficient cool air to allow most of the zones to be in control when the diffuser dampers are close to minimum position. Zones that are warmer can be controlled by the diffuser opening further. Zones that cannot be warmed sufficiently by reducing the cold air supply can be controlled by heating this reduced volume of air.

If the room temperature were to fall by 0.5°C below set point, the Triac Controller will commence energizing the heater proportionally and will fully energize the heater when the room temperature is approximately 1.5°C below set point.

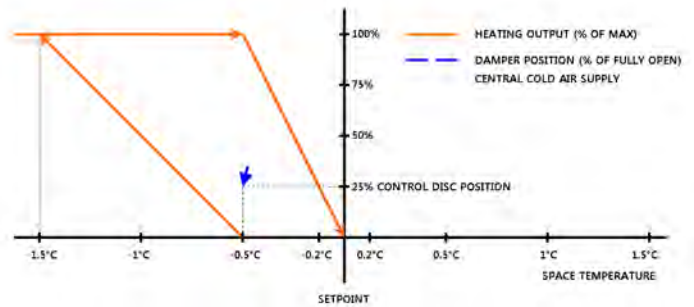

Integration of the Rickard VAV diffuser system with the central plant BMS is possible by using our MLM Interoperable BMS Compatible Controls.

PROPORTIONAL HEATING

For accurate control of room temperature, the electric re-heater is controlled on a step-less, proportional basis. In addition to having a proportional output signal for cooling control, the temperature controller also has a proportional output signal for heating.

This is done by means of a triac switching set (current valve) which varies the heater output capacity by cycling the power supply to the heater on and off – Pulse Width Modulation (PWM). This switching takes place over a cycle of approximately 2 seconds and always occurs at zero voltage to avoid radio frequency interference and voltage spikes. The "on" and "off" periods are varied in proportion to the amount of heating required, i.e. a required heating capacity of 75% will result in an "on" period of 1.5 seconds and an "off" period of 0.5 seconds.

CONTROLS

In a situation where multiple diffusers are controlled from a single controller, each diffuser will be fitted with its own triac that will receive a heating signal from the Master controller. The heating signal transmitted by the controller is a 9 Volt DC signal.

From the table "Maximum Recommended Heater Output (Watts)", it will be noted that for each neck total pressure there is a specific heater output quoted and for each diffuser size a standard heater capacity is referenced. For example, in the case of a VCD 250 diffuser, the re-heater sleeve would be factory fitted with a 1500 watt heater, which by utilizing the RICKARD MLM or MLM Interoperable BMS Compatible Controls, can be electronically set for any output from as little as 100 watts to 1500 watts to match the design engineer's requirements for minimum cooling mode supply air flow and desired leaving air temperature. Therefore, if the diffuser neck total pressure were to be set at 50Pa and the minimum desired air flow was 30% of maximum with 17°C air temperature rise, the heater output for a VCD 250 should be set to 1350 watts. Kindly refer to the help section in the MLM software program for more detailed information.

IMPORTANT ELECTRICAL INFORMATION: Electrical reticulation should be designed to have the capacity to manage the heaters full capacity e.g. when a heater is set to 50%, the heater element draws the same current as it would when set to 100% but it is drawn for 50% of the time.

SELECTION GUIDELINES

When calculating heater capacities for VAV diffusers, please keep in mind that heating in the cooling mode takes place when the diffuser is supplying minimum air flow and care must therefore be taken to ensure that an excessive temperature rise in the diffuser is avoided. Discharge temperatures in excess of 32°C are likely to cause stratification within the room. As a guide-line, the temperature of the air leaving the diffuser should not be more than 10°C above actual room temperature. Kindly refer to the appropriate products table giving the "Maximum Recommended Heater Output (Watts)" on page 3 for each diffuser size. These heater output ratings have been computed on the basis that minimum air flow is 30% of maximum and the maximum capacity of the fitted re-heater are set electronically for an air temperature rise of no more than 17°C, a standard feature of the RICKARD MLM and Interoperable BMS Compatible Controls.

IMPORTANT: These maximum capacities do not take into account limitations of the triac which are rated at 12A maximum. This reduces the capacity of the triac at low voltage supply.

ELECTRICAL AND OVERHEAT SAFETIES

Every Heater Module is fitted with a coiled Electrical Element inside a Mill Galvanised Sheet metal enclosure. The Heater Elements are "black heat" having a heat density of 3.2W/cm² and are constructed from an Incoloy material that does not glow red when energised. This element is selected to reduce the risk of combustible materials igniting should they come into contact with the heater element itself. No combustible materials are used in the construction of a Rickard Diffuser or Heater Module. Rickard uses a high spec flame retardant, self extinguishing polycarbonate plastic that is chlorine and bromine free and has a UL94 V-0 rating at 1.5mm in its ceiling diffusers. The Heater modules are fitted with their own Triac or Heater driver and receive a proportional signal from the diffuser controls when additional heating is required to bring the room into control. The Triac receives its power from a separate power circuit. Dedicated plug tops can be fitted to the heater module on request.

The Heater Modules Triacs are fitted with a number of safeties to reduce the risk of failure. The Triac is fitted inside an electrically grounded metal enclosure that is physically attached to the Heater module Enclosure. This safety increases the electrical safety of the device should a short circuit occur. A fuse offers additional protection against large current surges and shorts. A Transient suppressor prevents the Triac from failing closed and therefore driving the heater permanently after a voltage surge has occurred.

In all cases an auto-reset 65°±5°C (10 000 cycles) and power-reset 85°C±5°C (300 cycles) overheat safety cut-out is fitted as standard. The reset temperatures indicate the air temperature inside the over-heat safety cut-out casing at which it operates. Rickard heater modules are designed so that the overheat safety cut-outs trigger when the neck Total pressure is 30Pa or below. The trigger point can vary depending on a number of factors namely, excessively squashed or bent flex, neck size, heater size and damper position. Rickard controls do not activate its heaters below 20% flow damper position, thereby reducing the likelihood of the overheat safeties not triggering in the range described. The power reset cut-out is reset by turning the power supply off momentarily. If a power reset is required, an investigation into the cause should be made. Push-button type manual reset safeties are not recommended in conjunction with diffuser re-heaters.

STANDARD SAFETIES FITTED TO ALL VAV DIFFUSER TYPES

(VCD1, VSD1, CCD3, CSD3, VSW1, WBD's and VLN's)

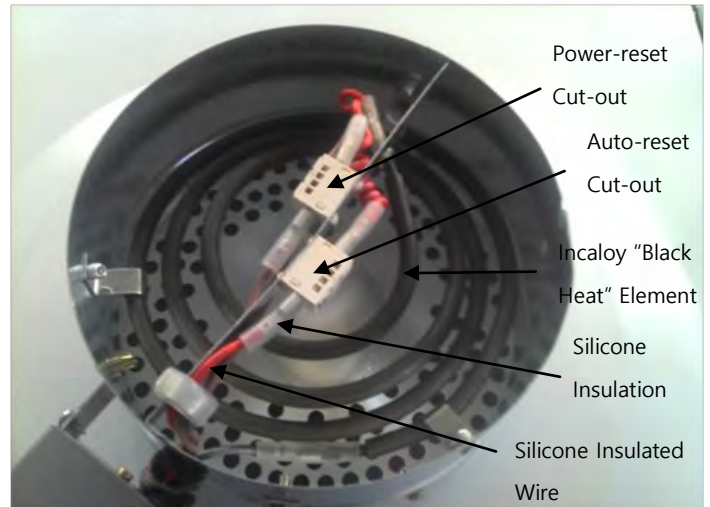

For additional safety, RICKARD offer an Airflow Switch to interrupt power to the re-heater controls when there is insufficient airflow across the heater element. The switch is calibrated to disable the heater current valve below a static pressure of 12Pa (+/- 5Pa). The switch operates as a dead man switch i.e. if the cable between the switch and the heater controls is unplugged, the heater will not operate.

OPTIONAL AIRFLOW CUT-OUT/SWITCH

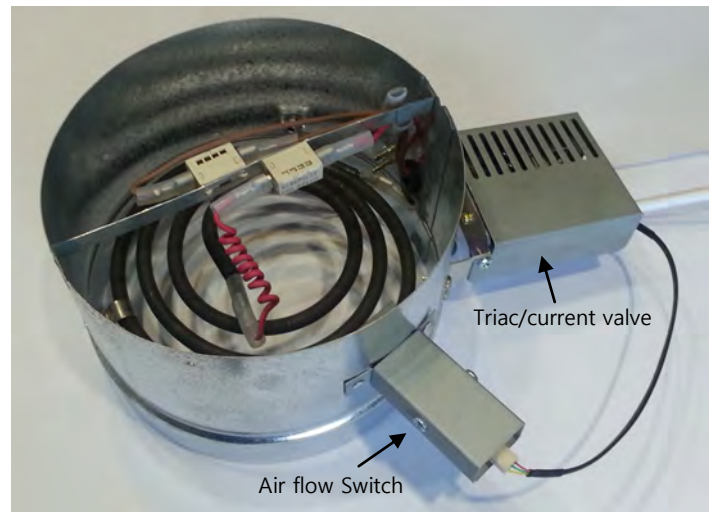

TESTING

All electrical wiring associated with the re-heater is carried out in the factory and all units carefully tested for correct operation.

OPTIONS

Heaters are available in various capacities, ranging from 0.5kW to 2.5kW.

For additional safety, RICKARD offer an Airflow Switch to interrupt power to the re-heater controls when there is insufficient airflow across the heater element.

Recommended Heater settings & sizing for a 15 Degree C Heat Rise @ 30% Open																			
VCD	Pa	20			30			40			50			60			70		
	Neck Size (mm)	kW			kW			kW			kW			kW			kW		
		Adjust	Fit	Set	Adjust	Fit	Set	Adjust	Fit	Set	Adjust	Fit	Set	Adjust	Fit	Set	Adjust	Fit	Set
	150	0.35	0.50	70%	0.34	0.50	68%	0.50	0.50	100%	0.50	0.50	100%	0.60	0.75	80%	0.65	0.75	87%
	200	0.60	0.75	80%	0.70	0.75	93%	0.75	0.75	100%	0.90	1.00	90%	1.00	1.00	100%	1.00	1.00	100%
	250	0.85	1.00	85%	1.00	1.00	100%	1.15	1.25	92%	1.30	1.50	87%	1.40	1.50	93%	1.50	1.50	100%
	300	1.00	1.00	100%	1.25	1.25	100%	1.50	1.50	100%	1.65	2.00	83%	1.75	2.00	88%	2.00	2.00	100%
	350	1.30	1.50	87%	1.50	1.50	100%	1.85	2.00	93%	1.85	2.00	93%	2.25	2.50	90%	2.50	2.50	100%

Recommended Heater settings & sizing for a 15 Degree C Heat Rise @ 30% Open																			
VSW	Pa	30			40			50			60			70					
	Neck Size (mm)	kW			kW			kW			kW			kW					
		Adjust	Fit	Set	Adjust	Fit	Set	Adjust	Fit	Set	Adjust	Fit	Set	Adjust	Fit	Set			
	150	0,35	0,5	70%	0,4	0,5	80%	0,45	0,5	90%	0,5	0,5	100%	0,55	0,75	73%			
	200	0,6	0,75	80%	0,7	0,75	93%	0,8	1	80%	0,85	1	85%	0,9	1	90%			
	250	0,85	1	85%	1	1,25	80%	1,1	1,5	73%	1,2	1,25	96%	1,3	1,5	87%			
	300	1	1	100%	1,2	1,5	80%	1,35	1,5	90%	1,5	1,5	100%	1,6	2	80%			

Recommended Heater settings & sizing for a 15 Degree C Heat Rise @ 30% Open																			
VLN1 2 Slot Pattern C	Pa	30			40			50			60			70					
	Length (mm)	kW			kW			kW			kW			kW					
		Adjust	Fit	Set	Adjust	Fit	Set	Adjust	Fit	Set	Adjust	Fit	Set	Adjust	Fit	Set			
	600	0,3	0,5	60%	0,35	0,5	70%	0,35	0,5	70%	0,4	0,5	80%	0,45	0,5	90%			
	900	0,45	0,5	90%	0,55	0,55	100%	0,6	0,75	80%	0,65	0,75	87%	0,7	0,75	93%			
	1200	0,65	0,75	87%	0,75	0,75	100%	0,8	1	80%	0,9	0,9	100%	1	1	100%			
	1500	0,85	0,85	100%	1	1	100%	1,1	1,25	88%	1,2	1,2	100%	1,3	1,5	87%			

Recommended Heater settings & sizing for a 15 Degree C Heat Rise @ 30% Open																			
WBD	Pa	20			30			40			50								
	Size (mm)	kW			kW			kW			kW								
		Adjust	Fit	Set	Adjust	Fit	Set	Adjust	Fit	Set	Adjust	Fit	Set						
	300/100	0,4	0,5	80%	0,5	0,5	100%	0,55	0,75	73%	0,6	0,75	80%						
	350/100	0,55	0,75	73%	0,65	0,75	87%	0,7	0,75	93%	0,75	0,75	100%						
	400/100	0,6	0,75	80%	0,75	0,75	100%	0,8	1	80%	0,9	1	90%						
	450/100	0,7	0,75	93%	0,8	1	80%	0,9	1	90%	1	1	100%						
	500/100	0,7	0,75	93%	0,85	1	85%	0,95	1	95%	1,1	1,25	88%						
	550/100	0,75	0,75	100%	0,95	1	95%	1,1	1,25	88%	1,2	1,25	96%						
	600/100	0,9	1	90%	1	1	100%	1,2	1,25	96%	1,25	1,25	100%						
	650/100	0,95	1	95%	1,15	1,25	92%	1,25	1,25	100%	1,45	1,5	97%						
	500/150	1	1	100%	1,25	1,25	100%	1,6	2	80%	1,8	2	90%						
	550/150	1,2	1,25	96%	1,4	1,5	93%	1,65	2	83%	1,85	2	93%						
	600/150	1,4	1,5	93%	1,6	2	80%	1,9	2	95%	2	2	100%						
	650/150	1,4	1,5	93%	1,7	2	85%	2	2	100%	2,2	2,5	88%						
	700/150	1,5	1,5	100%	1,85	2	93%	2,2	2,5	88%	2,4	2,5	96%						
	800/150	1,75	2	88%	2,1	2,5	84%	2,5	2,5	100%	2,5	2,5	100%						

Recommended Heater settings & sizing for a 10 Degree C Heat Rise @ 100% Open																			
CCD	Pa	20			30			40			50			60			70		
	Neck Size	kW			kW			kW			kW			kW					
		Adjust	Fit	Set	Adjust	Fit	Set	Adjust	Fit	Set	Adjust	Fit	Set	Adjust	Fit	Set			
	150	1.30	1.50	87%	1.50	1.50	60%	1.75	2.00	88%	2.00	2.00	100%	2.25	2.50	90%	2.40	2.50	96%
	200	1.80	2.00	90%	2.25	2.50	90%	2.50	2.50	100%	2.50	2.50	100%	2.50	2.50	100%	2.50	2.50	100%
	250	2.30	2.50	92%	2.50	2.50	100%	2.50	2.50	100%	2.50	2.50	100%	2.50	2.50	100%	2.50	2.50	100%
	300	2.50	2.50	100%	2.50	2.50	100%	2.50	2.50	100%	2.50	2.50	100%	2.50	2.50	100%	2.50	2.50	100%

Recommended Heater settings & sizing for a 10 Degree C Heat Rise @ 100% Open																			
CSW	Pa	20			30			40			50			60			70		
	Neck Size	kW			kW			kW			kW			kW					
		Adjust	Fit	Set	Adjust	Fit	Set	Adjust	Fit	Set	Adjust	Fit	Set	Adjust	Fit	Set			
	150	0.70	0.75	93%	0.80	1.00	80%	1.00	1.00	100%	1.00	1.00	100%	1.15	1.25	92%	1.25	1.25	100%
	200	1.20	1.25	96%	1.30	1.50	87%	1.50	1.50	100%	1.75	2.00	88%	1.90	2.00	95%	2.00	2.00	100%
	250	1.80	2.00	90%	2.00	2.00	100%	2.25	2.50	90%	2.50	2.50	100%	2.50	2.50	100%	2.50	2.50	100%
	300	2.00	2.00	100%	2.40	2.50	96%	2.50	2.50	100%	2.50	2.50	100%	2.50	2.50	100%	2.50	2.50	100%

To limit stratification in heating Rickard recommends that the heater outputs be limited to the values published in the tables above. The calculated values will ensure that the heat rise is no more than 15°C in VAV diffusers and 10°C in CAV diffusers. Please note that these values are a guide and are calculated at 30% volume for VAV diffusers and 100% volume for CAV diffusers. By adjusting the diffuser damper position down, a smaller volume will create a larger heat rise and therefore increase the likelihood of stratification. The Fit column indicates the maximum fitted heater size recommended, the Adjust value indicates the maximum heater setting recommended to achieve a 15°C (VAV) or 10°C (CAV) heat rise and the Set column is the MLM Heater Output % value required to achieve a 15°C (VAV) or 10°C (CAV) heat rise.